

## Caricamento - Loading

### Caricamento da sotto Bottom load magazine

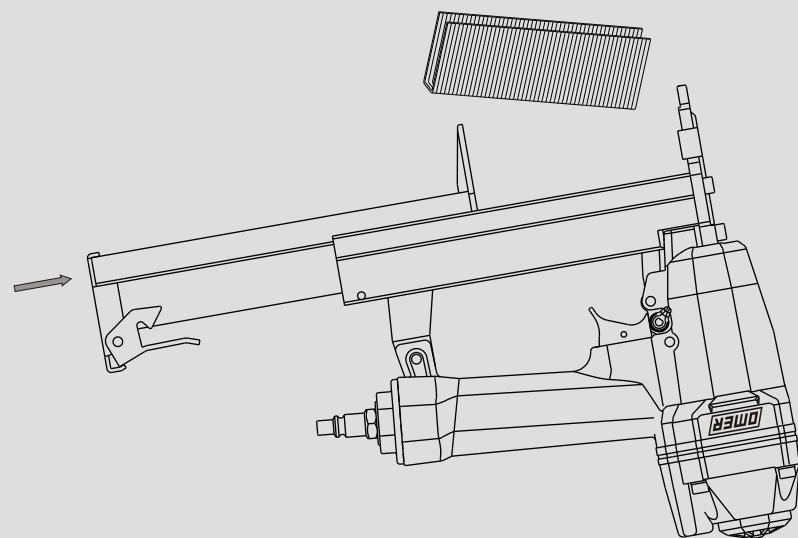
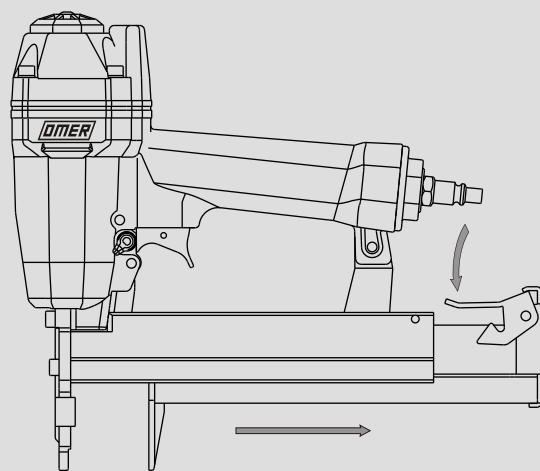

**-Premere il grilletto chiusura**  
Press the magazine latch

**-Arretrare il carrello**  
Pull the slider

**-Capovolgere la graffatrice**  
Turn the tool up side down

**-Inserire le graffe**  
Load the magazine with staples

**-Chiudere il carrello**  
Shut the slider



**Non azionare MAI il grilletto comando o la sicura a contatto durante il caricamento della graffatrice.**  
**NEVER pull the trigger or the contact safety while loading magazine.**

# OMER

Manuale d'uso, manutenzione e parti di ricambio

Parte 2

Use, maintenance and spare parts manual

Part 2

Gebrauchsanweisung, Instandhaltungsrichtlinien und Ersatzteile

Teil 2

Manuel d'utilisation, entretien et pièces de rechange

Partie 2

Manual de uso, mantenimiento y repuestos

Part 2

Manual de utilização, manutenção e partes sobresselentes

Parte 2

Handleiding voor gebruik, onderhoud en reservedeelsite

Deel 2

Brugsanvisning, vedligeholdelse og reservedeelsite

Del 2



## M2.38 B

cod. 1418230

1418230\_M238B\_1 160505

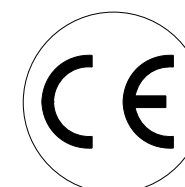

### Dati tecnici

Technical data  
Technische daten

### Données techniques

Datos tècnics

### Dados tècnics

Technische gegevens  
Tecniske data

#### Misure impiegabili mm

Usable lengths mm  
Gebrauchliche Längen mm

Mesures utilisable mm

Medidas que se pueden emplear mm

Medidas que se podem utilizar mm

Te gebruiken engtes in mm  
Brugbare laengder i mm

15 ÷ 40

#### Capacità caricatore n° punti

Magazine capacity No. of fasteners  
Magazinkapazität Nägel

Capacité chargeur n° de points

Capacidad cargador n° puntos

Capacitate carregador n° pontos

Capaciteit magazijn in aantal spijkers  
Kapacitet af magasin antal klemme

80

#### Pressione d'esercizio

Working pressure  
Betriebsdruck

Pression de fonctionnement

Presión de trabajo

Pressao de trabalho

Werkdruk

Arbejds tryk bar

5 ÷ 7,5 bar  
70 ÷ 105 psi

#### Consumo aria litri/colpo

Air consumption litres/shot  
Luftverbrauch Liter/Schlag

Consommation air litre/coup

Consumo aire-litros/golpe

Consumo ar litro/golpe

Luchtverbruik liter/schot

Luftforbrug liter/skud

0,54

#### Peso kg

Weight kg  
Gewicht kg

Poids kg

Peso kg

Peso kg

Gewicht in kg

Vaegt kg

1,50

#### Dimensioni (AxBxH) mm

Dimensions mm  
Größe mm

Dimension mm

Dimensiones mm

Dimencoes mm

Afmetingen in mm

Dimensioner mm

234x58x245

#### EN 12549 :1999 ISO 11201 :1995

#### Pressione sonora in pos. operatore

Sound pressure at the workstation  
Lärmintensität am Arbeitsplatz

Pression acoustique près de l'opérateur

Presión sonora en posición encargado

Intensidade sonora perto do operador

Geluidssterkte op de werkplek

Lydstyrke på operatorposten

$L_{pA,1s}$   
(Rif. 20µPa)

83,1 dB(A)

#### EN 12549 :1999 ISO 3744 :1994

#### Potenza sonora emessa

Emitted sound power  
Ausgestrahlte Lärmintensität

Puissance acoustique émise

Potencia sonora emitida

Potência sonora emitida

Uitgestraalde geluidssterkte

Udsendt lydstyrke

$L_{WA,1s}$   
(rif. 1pW)

92,9 dB(A)

#### EN 28662 :1992 ISO 5349 :1986 ISO 8662 -11

#### Valore medio ponderato di vibrazione sull'impugnatura

Weighted mean value of vibration on the grip

Mitteler Vibrationswert, am Griff  
Gemessen

Valeur moyenne pondérée de vibration mesurée sur la poignée

Valor medio ponderado de vibracion medida en la empunadura

Valor medio ponderado de vibracao medida no punho

Gewogen gemiddelde vibratiewaarde

Middelvaardi af vibrationer pa handtaget

Sequential  $a_{h,w}$

6,4 m/s<sup>2</sup>

Bump  $a_{h,w}$

6,06 m/s<sup>2</sup>

**Tipo di punto**  
Type of fastener  
Befestigungselement  
Type d'agrafe  
Tipo de punto  
Tipo de ponto  
Type nietjes  
Tilspændingstype

M2

1,40x1,60

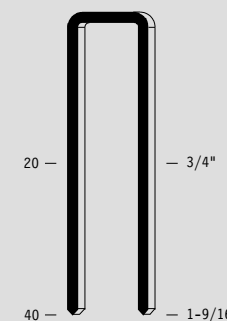

Gauge: 16

Crown: .420" (7/16")

## Caratteristiche - Features

### Colpo singolo Sequential fire

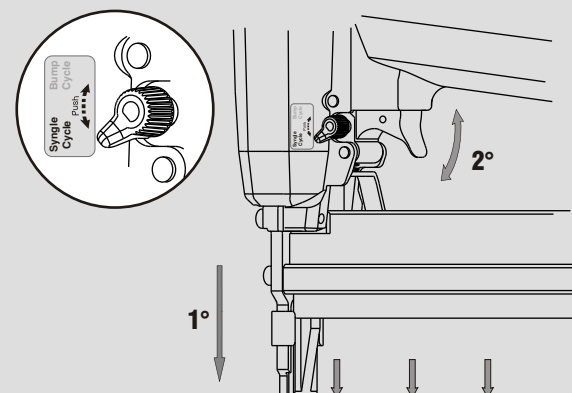

### Colpo martello Bump fire

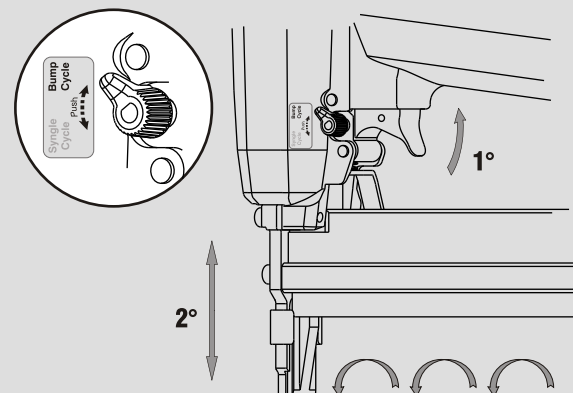

Parti di ricambio - Spare parts - Ersatzteile - Pièces de rechange - Piezas de repuesto  
- Partes sobresselentes - Tabel te raadplegen - Reservedele

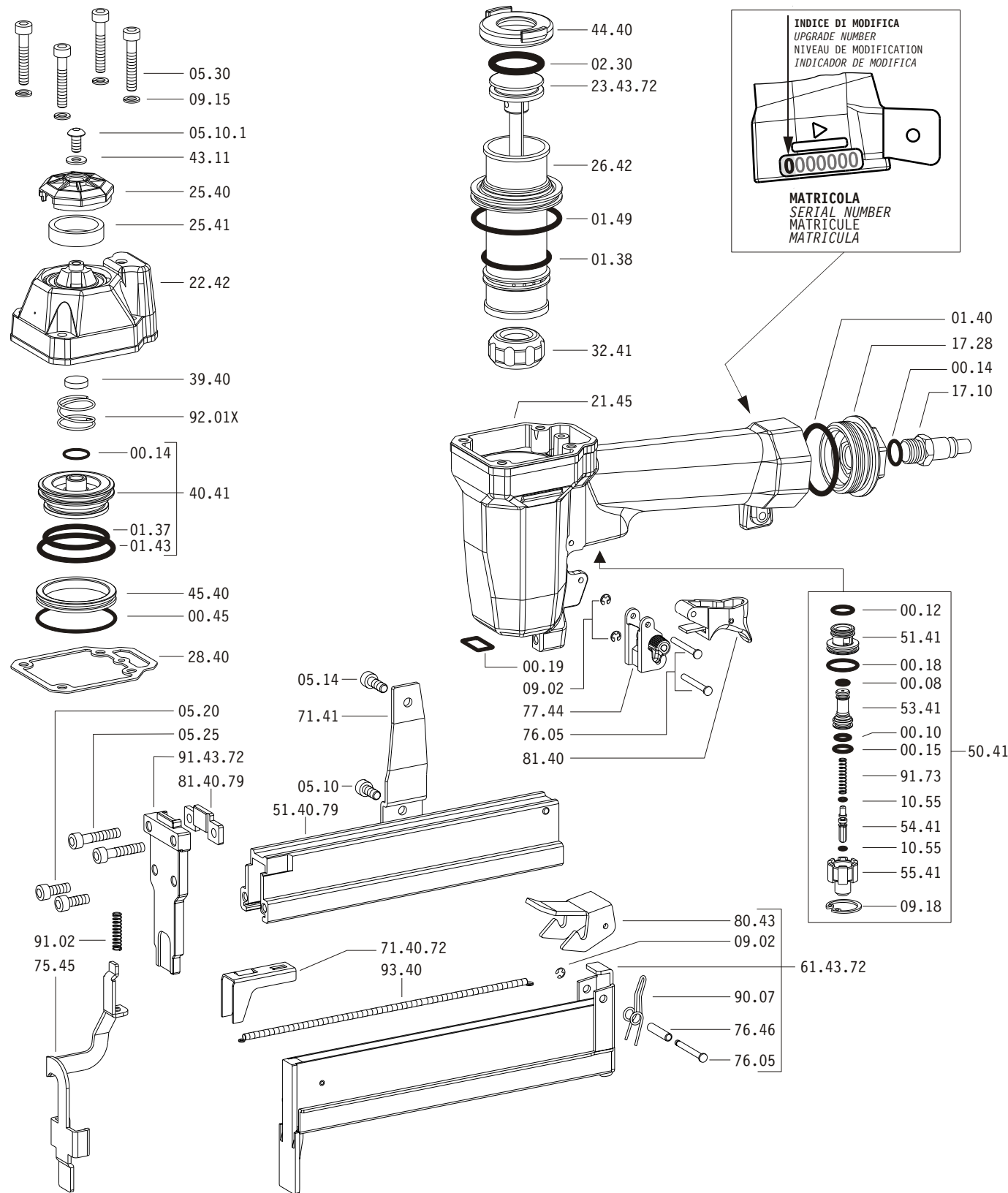

Dotazioni - Equipment - Ausrüstung - Équipements - Equipamiento - Equipamento - Uitrusting - Udstyr

Parti di ricambio - Spare parts - Ersatzteile - Pièces de rechange - Piezas de repuesto  
- Partes sobresselentes - Tabel te raadplegen - Reservedele

Cod.	Descrizione	Description
00.08	O-Ring	O-Ring
00.10	O-Ring	O-Ring
00.12	O-Ring	O-Ring
00.14	O-Ring	O-Ring
00.15	O-Ring	O-Ring
00.18	O-Ring	O-Ring
00.19	O-Ring	O-Ring
00.45	O-Ring	O-Ring
01.37	O-Ring	O-Ring
01.38	O-Ring	O-Ring
01.40	O-Ring	O-Ring
01.43	O-Ring	O-Ring
01.49	O-Ring	O-Ring
02.30	O-Ring	O-Ring
05.10	Vite	Screw
05.10.1	Vite	Screw
05.14	Vite	Screw
05.20	Vite	Screw
05.25	Vite	Screw
05.30	Vite	Screw
07.30	Chiave esagonale	Hex. bar wrench
07.40	Chiave esagonale	Hex. bar wrench
09.02	Anello elastico	Elastic ring
09.15	Rondella	Washer
09.18	Anello elastico	Elastic ring
10.55	O-Ring	O-Ring
17.10	Raccordo 1/4"	Air plug 1/4"
17.28	Tappo	Inlet cap
21.45	Corpo	Body
22.42	Testa	Head
25.40	Deflettore	Exhaust deflector
25.41	Silenziatore	Silencer
26.42	Cilindro	Cylinder
28.40	Guarnizione testa	Head gasket
32.41	Ammortizzatore	Bumper
39.40	Guarnizione scarico	Exhaust seal
40.41	Valvola completa	Valve ass'y
43.11	Rondella	Washer
44.40	Guarnizione	Gasket
45.40	Anello valvola	Ring
50.41	Pulsante completo	Trigger valve ass'y
51.41	Boccola pulsante	Trigger valve housing
53.41	Pistone servovalvola	Valve piston
54.41	Pulsante	Trigger valve
55.41	Raccordo pulsante	Bush
71.41	Reggicaricatore	Support
75.45	Sicura	Safety
76.05	Perno	Pin
76.46	Perno molla	Pin
77.44	Guida sicura	Safety guide
80.43	Grilletto chiusura	Trigger
81.40	Grilletto comando	Trigger
90.07	Molla	Spring
91.02	Molla	Spring
91.73	Molla	Spring
92.01X	Molla	Spring
93.40	Molla	Spring
23.43.72	Battente	Driver
51.40.79	Caricatore	Magazine
61.43.72	Carrello	Slider
71.40.72	Spingipunto	Pusher
81.40.79	Controtestina	Nose
91.43.72	Testina	Nose plate
D01	Boccetta olio	Oiler

-Kit deo-rings - O-ringen - Pakringer

Guarnizioni - O-Rings - Dichtungen - Joints - Empaquetadura de anillo -

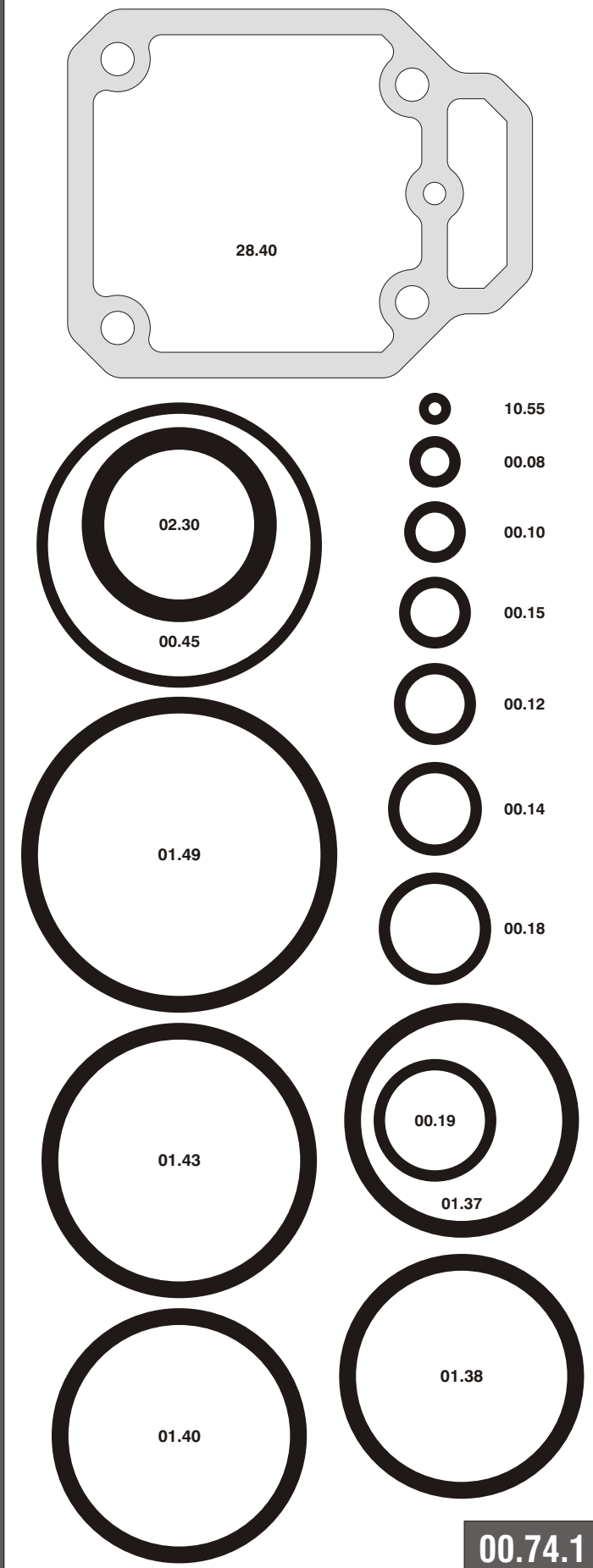

1418230\_M238B\_1\_160505

**M2.38 B**

cod. 1418230

Indice di modifica Upgrade number

**1**

1137498