



Manuale d'uso, manutenzione e parti di ricambio
Use, maintenance and spare parts manual
Gebrauchsanweisung, Instandhaltungsrichtlinien und Ersatzteile
Manuel d'utilisation, entretien et pièces de rechange
Manual de uso, mantenimiento y repuestos
 Εγχειρίδιο χρήσης, συντηρησης και ανταλλακτικών
Manual de utilização, manutenção e partes sobresselentes
Handleiding voor gebruik, onderhoud en reservedelslste
Brugsanvisning, vedligeholdelse og reservedelslste

Parte 2
Part 2
Teil 2
Partie 2
Part 2
 2º Μερως
Parte 2
Deel 2
Del 2



90.40

cod. 1717000

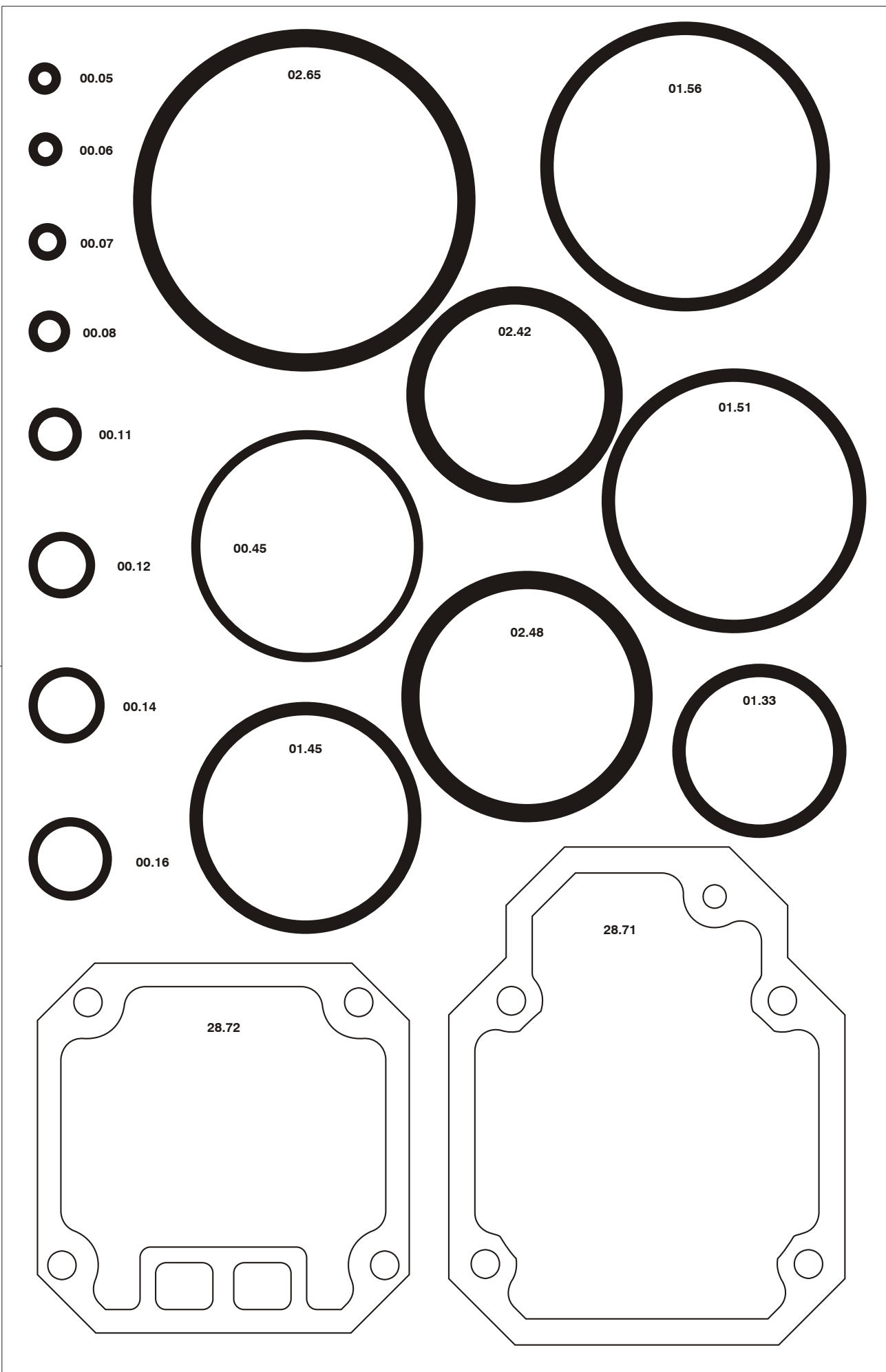

00.77.1

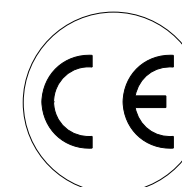

Dati tecnici Technical data Technische daten	Données techniques Datos tècnicos Τεχνικα χαρακτηριστικα	Dados tècnicos Technischegegevens Teknische data
Misure impiegabili mm Usable lengths mm Gebrauchliche Längen mm	Mesures utilisable mm Medidas que se pueden emplear mm Διαστασεις σε μμ	Medidas que se podem utilizar mm Te gebruiken engtes in mm Brugbare laengder i mm
Capacità caricatore n° punti Magazine capacity No. of fasteners Magazinkapazität Nägel	Capacité chargeur n° de points Capacidad cargador n° puntos Δυνατοτητα γεμιστερα, σπινδυτερσ	Capacitade carregador n° pontos Capaciteit magazijn in aantal spijkers Kapacitet af magasin antal klemmme
Pressione d'esercizio Working pressure Betriebsdruck	Pression de fonctionnement Presión de trabajo Πιεση λειτουργιασ ατμ.	Pressao de trabalho Werkdruk Arbejds tryk bar
Consumo aria litri/colpo Air consumption litres/shot Luftverbrauch Liter/Schlag	Consommation air litre/coup Consumo aire-litros/golpe Καταναλοση αερα λ/ξτπημα	Consumo ar litro/golpe Luchtverbruik liter/schot Luftforbrug liter/skud
Peso kg Weight kg Gewicht kg	Poids kg Peso kg Βαρος κγ	Peso kg Gewicht in kg Vaegt kg
Dimensioni (AxBxH) mm Dimensions mm Größe mm	Dimension mm Dimensiones mm Δυνατοτητα γεμιστερα , σπινδυτερσ	Dimencoes mm Afmetingen in mm Dimensioner mm
ISO 11201 Pressione sonora in pos. operatore Sound pressure at the workstation Lärmintensität am Arbeitsplatz	ISO 11201 Pression acoustique près de l'opérateur Presión sonora en posición encargado Ακουστικη πιεση στη θεση χειριστου	ISO 11201 Intensidade sonora perto do operador Geluidssterkte op de werkplek Lydstyrke på operatorposten
ISO 3744 Potenza sonora emessa Emitted sound power Ausgestrahlte Lärmintensität	ISO 3744 Puissance acoustique émise Potencia sonora emitida Ακουστικη ισχυ	ISO 3744 Potência sonora emitida Uitgestraalde geluidssterkte Udsendt lydstryrke
ISO 5349-86 Valore medio ponderato di vibrazione sull'impugnatura max.33 colpi Weighted mean value of vibration on the grip max.33 shots Mitteler Vibrationswert, am Griff gemessen max.33 Schäge	ISO 5349-86 Valeur moyenne pondérée de vibration mesurée sur la poignée max.33 coups Valor medio ponderado de vibracion medida en la empuñadura max.33 golp Μεσος ορος μετρησις κραδασιμων στη χειρολαβη μαξ.33 ξτπημα	ISO 5349-86 Valor medio ponderado de vibracao medida no punho max.33 golpes Gewogen gemiddelde vibratiewaarde max.33 schot Middelvaardi af vibrationer pa handtaget max.33 skud

Tipo di punto
Type of fastener
Befestigungselement
Type d'agrafe
Tipo de punto
Τυπος καρφιου
Tipo de ponto
Type nietjes
Tilspændingstype

90
1,00x1,25

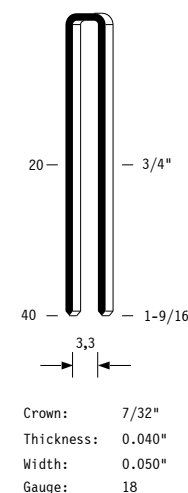

Parti di ricambio - Spare parts - Ersatzteile - Pièces de rechange - Piezas de repuesto
Ανταλλακτικά - Partes sobresselentes - Tabel te raadplegen - Reservededele

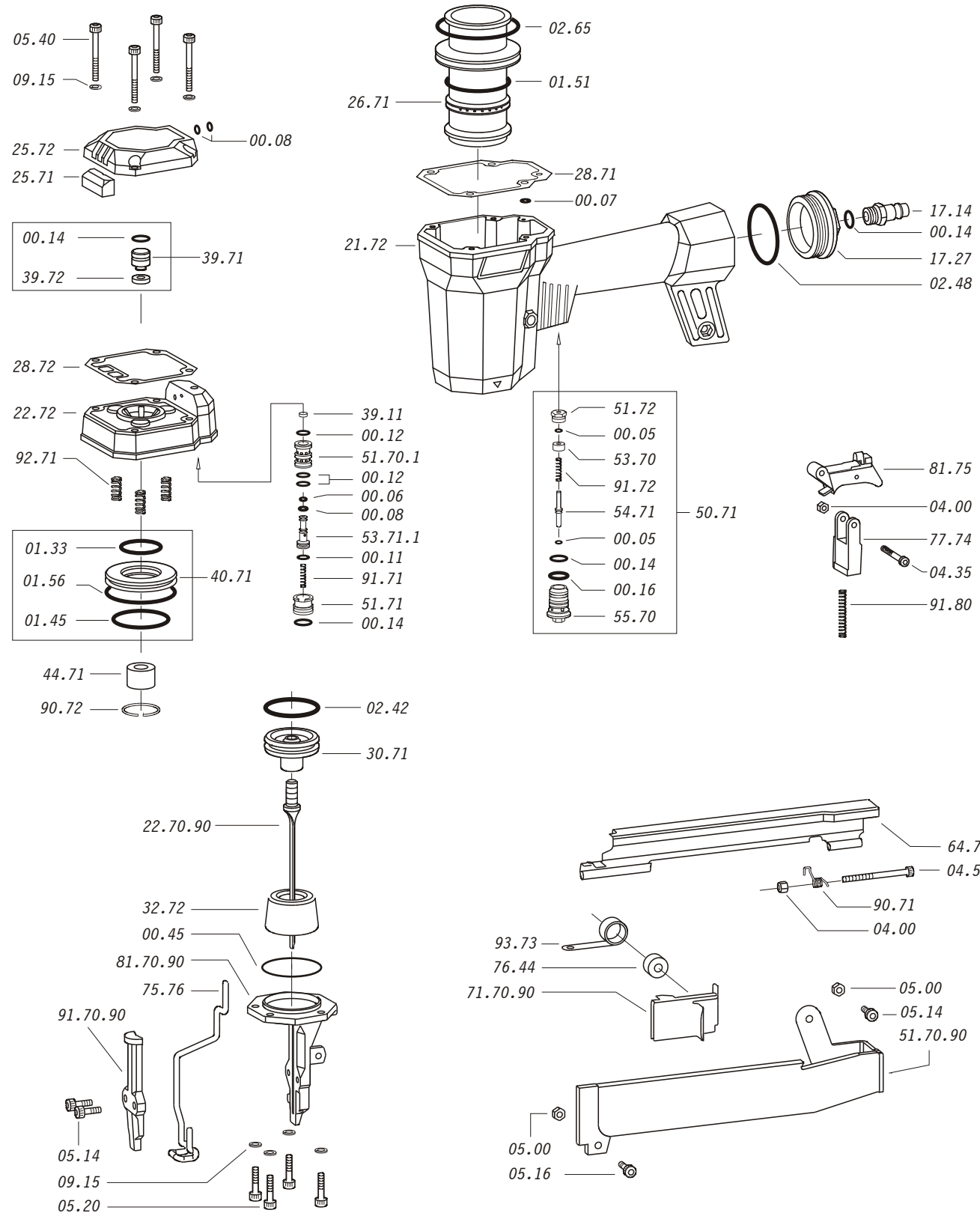

Dotazioni - Equipment - Ausrüstung - Équippements - Equipamiento - Παρεχόμενα
Equipamento - Uitrusting - Udstyr

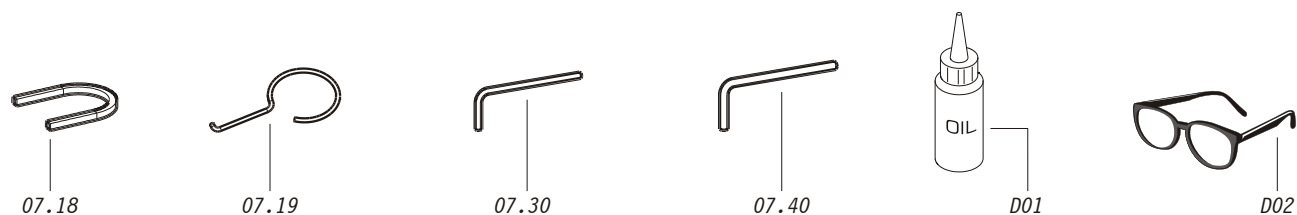

Parti di ricambio - Spare parts - Ersatzteile - Pièces de rechange - Piezas de repuesto
Ανταλλακτικά - Partes sobresselentes - Tabel te raadplegen - Reservededele

Cod.	Descrizione	Description
00.05	O-Ring	O-Ring
00.06	O-Ring	O-Ring
00.07	O-Ring	O-Ring
00.08	O-Ring	O-Ring
00.11	O-Ring	O-Ring
00.12	O-Ring	O-Ring
00.14	O-Ring	O-Ring
00.16	O-Ring	O-Ring
00.45	O-Ring	O-Ring
01.33	O-Ring	O-Ring
01.45	O-Ring	O-Ring
01.51	O-Ring	O-Ring
01.56	O-Ring	O-Ring
02.42	O-Ring	O-Ring
02.48	O-Ring	O-Ring
02.65	O-Ring	O-Ring
04.00	Dado	Nut
04.35	Vite	Screw
04.50	Vite	Screw
05.00	Dado	Nut
05.14	Vite	Screw
05.16	Vite	Screw
05.20	Vite	Screw
05.40	Vite	Screw
07.18	Chiave pistone	Piston wrench
07.19	Estrattore	Extractor
07.30	Chiave esagonale	Hex. bar wrench
07.40	Chiave esagonale	Hex. bar wrench
09.15	Rondella	Washer
17.14	Raccordo 1/4"	Air plug 1/4"
17.27	Tappo	Inlet cap
21.72	Corpo (specificare il colore)	Body (to specify the colour)
22.72	Testa	Head
25.71	Silenziatore	Silencer
25.72	Deflettore scarico	Exhaust deflector
26.71	Cilindro	Cylinder
28.71	Guarnizione testa	Head gasket
28.72	Guarnizione testa	Head gasket
30.71	Pistone	Piston
32.72	Ammortizzatore	Bumper
39.11	Guarnizione servovalvola	Servo valve gasket
39.71	Valvola scarico completa	Exhaust valve assembled
39.72	Guarnizione valvola scarico	Exhaust valve gasket
40.71	Valvola completa	Valve assembled
44.71	Ammortizzatore sup.	Upper bumper
50.71	Pulsante completo	Trigger valve assembled
51.70.1	Cilindro servovalvola	Servo valve cylinder
51.71	Boccola servovalvola	Servo valve bushing
51.72	Premistoppa	Stuffing box
53.70	Distanziale	Spacer
53.71.1	Pistone servovalvola	Servo valve piston
54.71	Pulsante	Trigger valve
55.70	Raccordo	Trigger valve bush
64.71	Carter	Hold down
75.76	Sicura	Safety
76.44	Rullo molla	Roller
77.74	Guida sicura	Safety guide
81.75	Grilletto comando completo	Trigger assembled
90.71	Molla	Spring
90.72	Molla	Spring
91.71	Molla	Spring
91.72	Molla	Spring
91.80	Molla	Spring
92.71	Molla	Spring
93.73	Molla	Spring
22.70.90	Battente	Driver
51.70.90	Caricatore	Magazine
71.70.90	Spingipunto	Pusher
81.70.90	Controtestina	Nose
91.70.90	Testina	Nose plate
D01	Bocchetta olio	Oiler
D02	Occhiali protettivi	Protective goggles

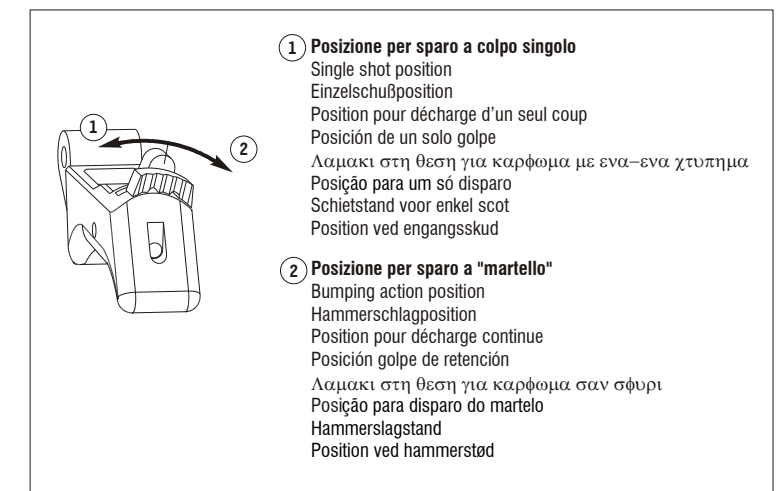
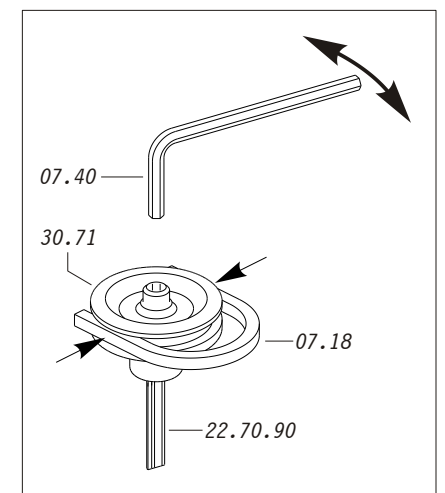
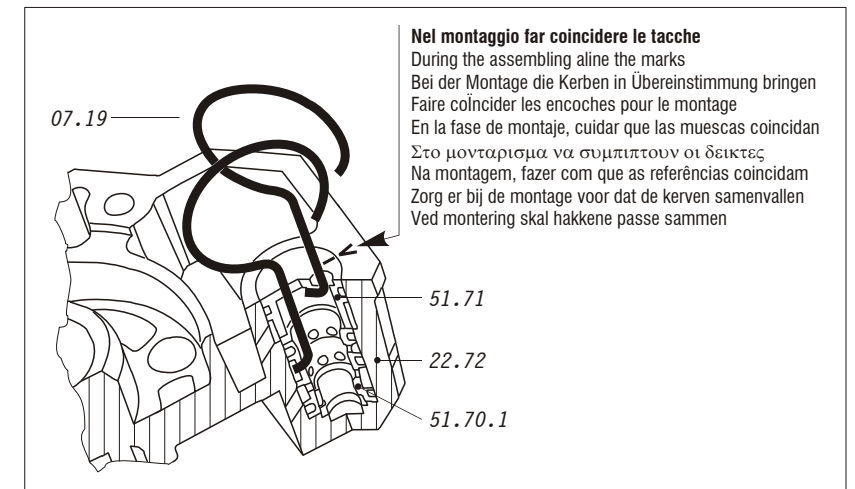

1717000_9040_1_070700

90.40

cod. 1717000

Indice di modifica
Upgrade number

1